

SPECIFICATIONS

Electrical:

- 1.Current Rating: 1.5A / contact terminal
- 2.Voltage Rating: 30V DC
- 3.Contact Resistance: 30 milliohms Max
- 4.Dielectric Withstanding Voltage: 500 V AC AT Sec Level
- 5.Insulation Resistance: 1000 MEGA ohms Min
- 6.Operating Temperature: -40°C~85°C

Mechanical:

- 1.Connector Mate and Unmate Force
Mate force: 3.57 kgf (Max)
Unmate force: 1.02 kgf (Min)
- 2.Terminal Retention: 1.2 kgf (Min)

Material:

- 1.Housing:High Temperature Thermal Plastics,
- 2.Contact: BRASS
- 3.Shell: BRASS / SPCC

Finish:

- 1.Contact: Plated Gold in Mating Area ;
Tin Plated on Solder Balls ;
Nickel under plated overall
- 2.Shell: Nickel under Plated surface layer

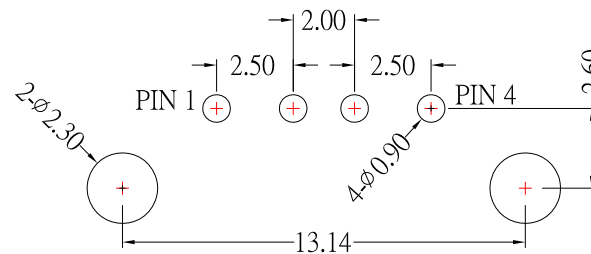
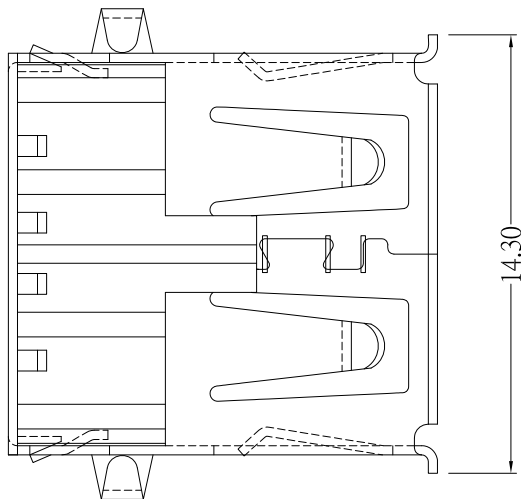

SUA-110H6x-xx-S175

SHELL MATERIAL :

Blank : BRASS
I : SPCC

Color :

B	Black :Housing : LCP
W	White:Housing : PBT
BL	Blue:Housing : PBT

鍍層厚度 :

Blank : 1u"
2 : 15u"
3 : 30u"

8	新增Operating Temperature	Jack	052418	10	更新顏色材質選項	Jack	101620
7	新增PIN電路標示	Jack	122016	9	更新Operating Temperature	Jack	052518

6	新增PIN標示	Jack	102214
5	新增7.45的尺寸	Jack	081514
4	新增6.80的尺寸	Jack	052714
3	新增10.20的尺寸	Jack	051614
2	更新料號及材質和鍍層	Jack	112913
1	新增鍍層選項	Jack	072613
ITEM NO.	DESCRIPTION	DRAWN	DATE

東莞市高迪電子有限公司
DONG GUAN GAO DI ELECTRONICS CO., LTD

TOLERANCE UNLESS OTHERWISE STATED :
Up to 5 ±0.2
Above 5 ~ 15 ±0.3
Above 15 ~ 30 ±0.4
Above 30 ~ 50 ±0.5
Angle ±0.3

3RD. ANGEL'S

UNITS MM

DRAWN BY:	DATE	MAT'L	TITLE	CONNECTOR
Jack Lu	10/16/20			
CHECKED BY:	DATE	FINISH	MODLE	USB AF DIP TYPE
Jacky Chen	10/16/20			
APPROVED BY:	DATE	SCALE	DWG NO.	SUA-110H6x-xx-S175
Tony Kao	10/16/20	1 : 1	PART NO.	SUA-110H6x-xx-S175
		SHEET NO.	1 of 1	SIZE A4
				VER A10